



THE ULTIMATE SUN BLOCK™

EXTERIOR SOLAR SCREENS

SCREEN MANUAL

For Owners and Operators
of Eclipse Shading Systems

• Instructions • Maintenance • Warranty Information •

OPERATING YOUR MOTORIZED SCREENS

Your screen can operate individually with its own remote, or on a specified channel for multi channel remotes, if equipped.

For single channel controller:

Only a single channel indicator light exists. All units operate with a single command.

For multi-channel controller:

Press and release the CHANNEL BUTTON until the desired channel indicator light is lit.

To raise screen:

Press and release the UP BUTTON. The screen will lift and stop at the preset upper limit. To stop the screen before it reaches the upper limit, press and release the MY or STOP button at the desired height.

To lower screen:

Press and release the DOWN BUTTON. The screen will stop at the preset lower limit. To stop the screen before it reaches the lower limit, press and release the MY or STOP button at the desired height.

MULTI-CHANNEL REMOTE

**Your Remote may differ in appearance.*

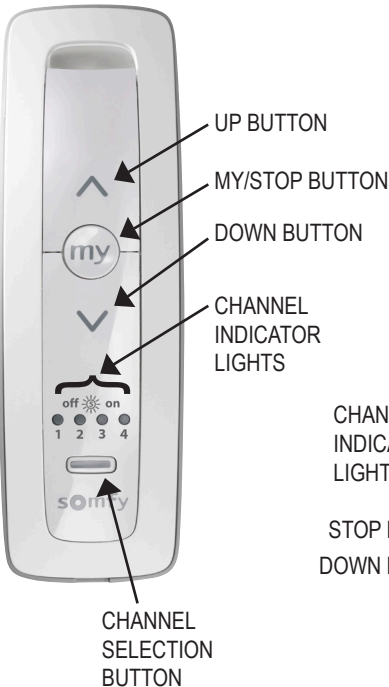

MULTI-CHANNEL WALL MOUNT

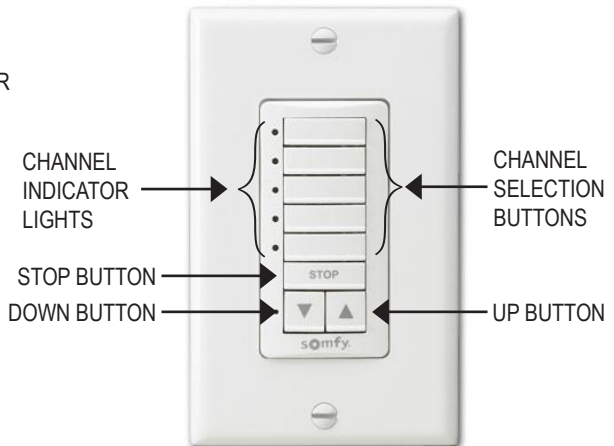

OPERATING YOUR MANUAL SCREENS

For manual, hard crank operation:

Carefully place the end of the crank handle into the eye of the gear. Turn the handle until the hem bar reaches the bottom of the track or the cable anchor. The fabric should appear taut and not become slack due to overextending it. Overextending the fabric can cause damage.

When retracting, stop turning the handle when the top of the hem bar reaches the top of the tracks or the bottom of the cassette box (if unit is equipped with one). Overretracting the fabric will cause the fabric to come out of the guides (on Zipper Screens) and become nonfunctional. On other units, it can damage the fabric as well as the mechanical parts.

When not operating the screen, it is strongly suggested that you remove the crank handle from the gear eye. This is to avoid the handle swinging around, and possibly causing damage to the fabric or dropping out of the gear eye. Safely store the handle away from the unit.

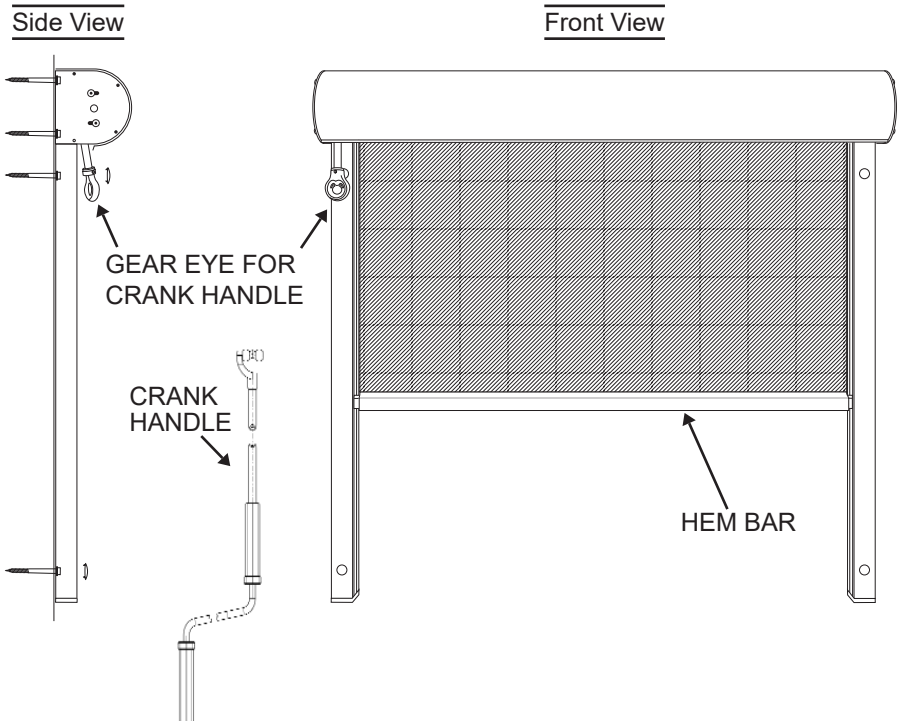

SPECIAL CARE FOR ZIPPER SCREENS WITH OPTIONAL CLEAR WINDOWS



CLEANING & MAINTENANCE:

The vinyl windows should be cleaned and protected every other month using only Imar's Clear Vinyl Clean & Protect product. The "protect part" will prevent the vinyl from sticking in hot humid weather when retracted.

To purchase this product in quarts and gallon containers, search the web for the term: "Imar's Clear Vinyl Clean & Protect #313"

USAGE:

Eclipse Screens with clear vinyl windows should remain retracted/closed if the temperature drops below 40 degree. Operating your screen(s) below 40 degrees can/will damage the vinyl window and will void your warranty.

WARRANTY:

Eclipse Premium Windows are constructed of the highest quality, press polished vinyl and carry a non-extendable 1 year warranty. Eclipse standard windows are made from rolled vinyl goods and carry a 90 day non-extendable warranty. This warranty covers cracking only.

Please note that the following is NOT COVERED by any Eclipse warranty: yellowing, scratches, waviness, wrinkling, improper use and improper cleaning.

IMPORTANT NOTES:

In warmer weather, the windows will expand and cause some waviness. If the units are retracted when wet or in high humidity, they may appear cloudy. This cloudiness will go away when left down in the sun.

PROPER CARE, MAINTENANCE & IMPORTANT ITEMS CONCERNING YOUR SCREEN UNIT(S)

- When lowering the screen, ensure that it is not obstructed in any way. Obstructions can cause damage to the unit.
- When lowering the screen, if the bottom bar should get jammed or stop moving (which may also occur in very windy conditions), immediately hit the MY or STOP button on your controller.
- Your motorized screen will not operate if there is a loss of power.
- When your screen is not in use, we recommend fully retracting it.
- Do not operate screen in below freezing temperature.
- Do not cook near or expose the screen fabric to high heat.
- **For Zipper Screens** - the side retention fabric guides are located inside each of the side tracks. These guides should be free of dirt or debris, an occasional hosing off is recommended. After cleaning, you may want to carefully spray some dry lube on the black plastic fabric guides slots located in the tracks to ensure smooth and quiet operation.
- Your screen fabric can be cleaned with a mild detergent in warm water and soft brush. Let the screen fabric dry completely before retracting.
- In very strong winds, your screen should be retracted to avoid damage to the unit and the fabric.
- For manually operated screens - when retracting, stop turning the crank handle once the top of the hem bar reaches the top of the tracks. Over-retracting the fabric will cause the unit not to function correctly and/or can damage the fabric.
- Do not attach anything to the fabric as it will cause damage when the unit is retracted.
- In case of a power outage and the screens are down, the hem bar can be carefully lifted to provide an exit. If this needs to be done, avoid simply dropping the hem bar to prevent fabric damage.



LIMITED PRODUCT WARRANTY

Exterior Solar Screens

We at Eclipse stand behind our exceptional shading products with pride. Should any products purchased from Eclipse become defective, we will replace or repair them free of charge under the following terms of our **limited warranty**:

SCREEN HARDWARE/HOUSING

These components are guaranteed to function free from defects in workmanship and materials, under proper use, for 10 years from the original date of purchase. The hardware finish is warranted for 5 years when installed a distance greater than 1 mile from the ocean.

SCREEN FABRIC

The fabric is guaranteed from becoming unserviceable due to loss of color or strength from normal exposure conditions, including: sunlight, mildew, rot and atmospheric chemicals, for 10 years from the original date of purchase on most fabrics (some are only 5 years - ask your dealer for more details).

MOTORS, CONTROLS & ELECTRONICS

These components (some are optional) are warranted to be free from defects in materials and workmanship, under normal and proper use, for a period of 5 years from the original date of purchase.

WARRANTY EXCLUSIONS

LIMITED LIABILITY & INDEMNIFICATION

Eclipse will not be liable for any consequential or incidental damages or injuries arising from an alleged breach of this within limited warranty. Eclipse assumes no liability for damage to these products and/or component parts caused by faulty installation, reinstallation or service. Eclipse is not responsible for damage to any structure to which these products are installed on or attached to or to any personal property or items located above, below or near the screen. Further, this warranty is void if the screen is sold, serviced, or repaired by any unauthorized dealer or service outlet. Purchaser shall defend, indemnify, and hold Eclipse harmless against all claims, suits, proceedings, losses, liabilities, and damages (including costs, expenses, and reasonable attorneys' fees) asserted by third parties against the Purchaser which arise out of any act or omission that constitutes a breach of Purchaser's warranties hereunder.

FORCE MAJEURE

Eclipse is not responsible to cover damage to the Screen unit or its component parts caused from acts of nature, such as hurricanes, gales, snow, sleet, tornadoes, heavy rain, heavy winds, hail, flooding, fire, or similar hazards.

ADDITIONAL EXCLUSIONS

Eclipse is not responsible to cover the cost of damage due to vandalism, neglect, improper use or care (or a combination of the foregoing), dents, scratches, degradation due to salt (corrosion, oxidation, rust, chipping, peeling of paint finish), or weathering occurring from normal use, wear and tear (on all related products).

***PLEASE NOTE**

This warranty does not cover labor costs associated with or limited to: inspections, repairs, adjustments or component replacements.

This warranty is **NON-TRANSFERRABLE** and **Labor is Not Included**.

NOTES:

DEALER CONTACT INFO:

To factory register your Eclipse Shading System, visit:

eclipseawning.com/home/warranty-registration

(see Eclipse Owners tab at eclipseawning.com)

Enter your order number as shown in the box below



Eclipse
1760 Route 211 East
Middletown, NY 10941
800-501-3850
eclipseawning.com